

Omni Fleet: Your Complete Material Handling Suite

Better Performance, Better Value



The future is faster.
The future is stronger.
The future is smarter.

Nicolas Chee
Founder and CEO
ForwardX Robotics



Contents

Solutions

Fulfillment	4
Case Study: JD.com	6
Distribution	8
Case Study: DHL	10
Case Study: ITOCHU	12
Manufacturing	14
Case Study: TCL	16
Automotive	18
Case Study: SERES	20

Products

Matrix Automation Platform	22
Flex AMRs	24
Conveyor AMRs	28
Max AMRs	30
Lynx AMRs	32
Apex AMRs	34
Reflex Charging Station	36
f(x) Fleet Manager Software	38

About ForwardX	40
----------------	----



Fulfillment

Workflows

Piece Picking

Use Flex AMRs for batch picking or discrete order picking of small individual items.

Case Picking

Use Flex or Max AMRs for larger individual items or case loads of smaller items.

Pick and Pack

Use Flex or Max AMRs to pick and place items directly into packing containers and apply shipping labels on the fly.

Your Current Pain Points

Low Productivity

Rising ecommerce volume means more orders and pieces to pick. The traditional manual methods are slow, labor intensive, and restrictive.

High Labor Costs

Piece picking requires more space and more labor. Traditional operations spend more money to hire and retain workers, and this results in lower margins.

Low Efficiency

Wasted movement is wasted time and wasted money. Traditional operations are limited by low efficiency and need smart automation.

High Error Rate

Manual methods cause errors, and errors waste time and money. Errors also result in a poor customer experience, and error resolution is costly.



Industries



3PL



Omnichannel



Ecommerce

Results We Deliver

Productivity: 2x–3x UPH Increase

ForwardX solutions increase productivity through consolidated workflows that reduce wasted time and increase output. Double or even triple your pickers' units picked per hour by removing insignificant tasks.

Accuracy: Up to 99.9% Picking Accuracy

Instead of pick lists, f(x) organizes and distributes orders directly to employees. Use on-screen visual directions and onboard RFID scanning, so your workers can pick correctly the first time, every time.

Payback: ROI in Under 9 Months

ForwardX solutions deliver immediate results. See a marked improvement and financial gain in under 2 weeks, and get a guaranteed return on investment in less than 9 months.

Efficiency: 60% Reduction in Walking Time

AMRs handle material movements, allowing employees to focus on more important tasks. Reduce traveling, picking, and order reviewing time to achieve more in a shorter period.

Savings: 50% Reduction in Labor Costs

AMRs address recruitment and turnover issues by increasing productivity and worker satisfaction. Automate repetitive workflows and redistribute your work force to cut your fully burdened labor costs in half.

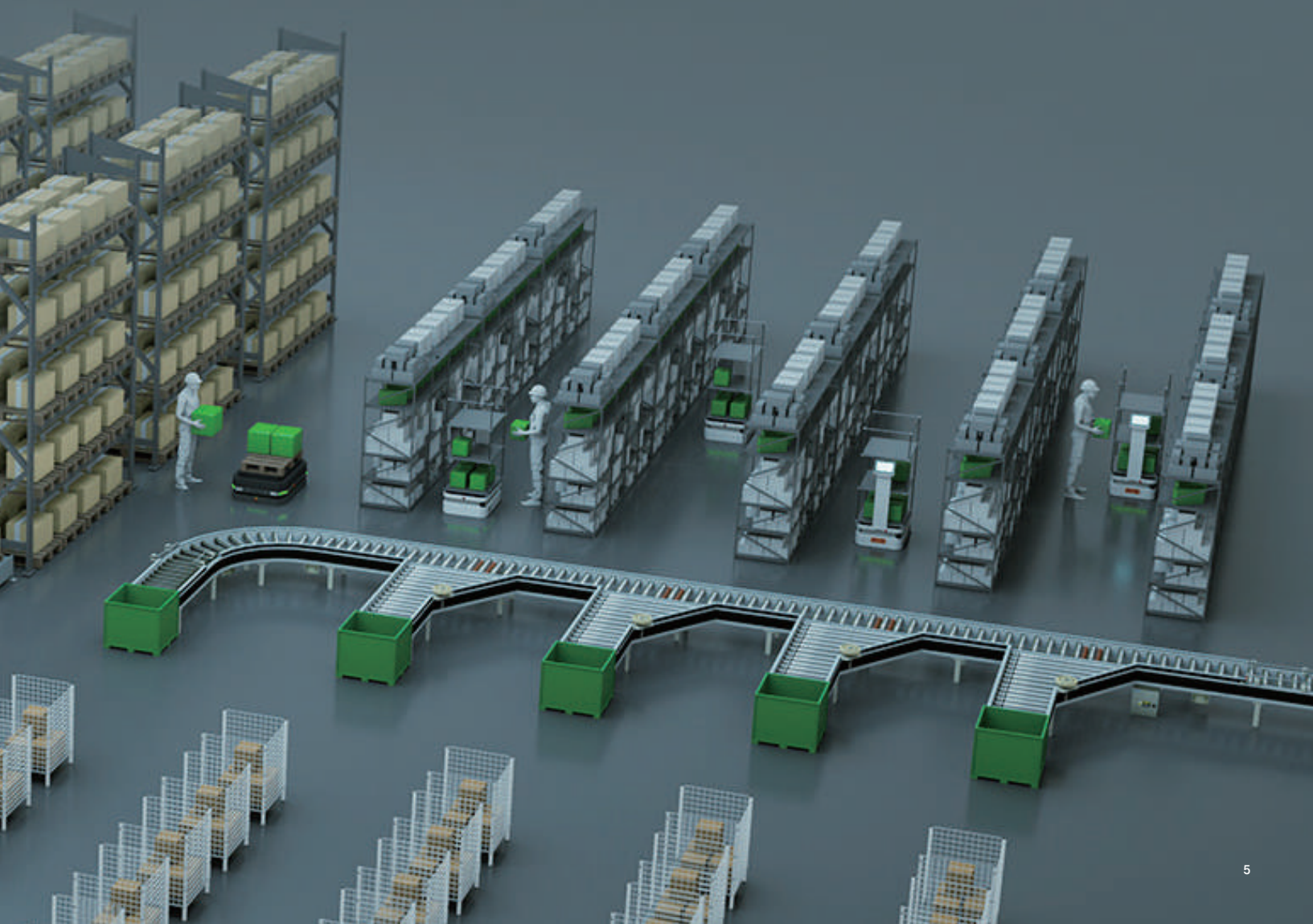

JD.com

JD.com chose a ForwardX Max solution for case picking workflows in both B2B retail store replenishment and B2C ecommerce fulfillment. The Max solution consists of Max 600 AMRs to increase picking efficiency and reduce high labor turnover, due to the physically demanding nature of case picking. After the flagship project, over 30 more projects of this nature have been deployed with JD Logistics.

Results

2.36x

Productivity Increase

~4,000

Daily Orders

>30

More Projects Deployed
Since Flagship Project



Distribution

Workflows

Piece Picking

Use Flex AMRs for batch picking or discrete order picking of small individual items.

Case Picking

Use Flex or Max AMRs for larger individual items or case loads of smaller items.

Pallet Picking

Use Max AMRs to pick direct to pallets.

Pick and Pack

Use Flex or Max AMRs to pick and place items directly into packing containers and apply shipping labels on the fly.

Your Current Pain Points

High Labor Intensity

Distribution environments can be harsh, and workflows can be physically draining. High labor intensity results in errors and worker turnover.

High Labor Costs

Labor intense work means high labor and recruitment costs. Traditional methods squeeze profit margins and are at the mercy of a growing labor shortage.

Low Efficiency

Traditional methods are time-consuming and inefficient. Changing logistics network design results in a need for faster and more efficient workflows.

Safety Concerns

Heavy goods in larger quantities means safety risks, and traditional forklift methods contribute to rising instances of accidents.

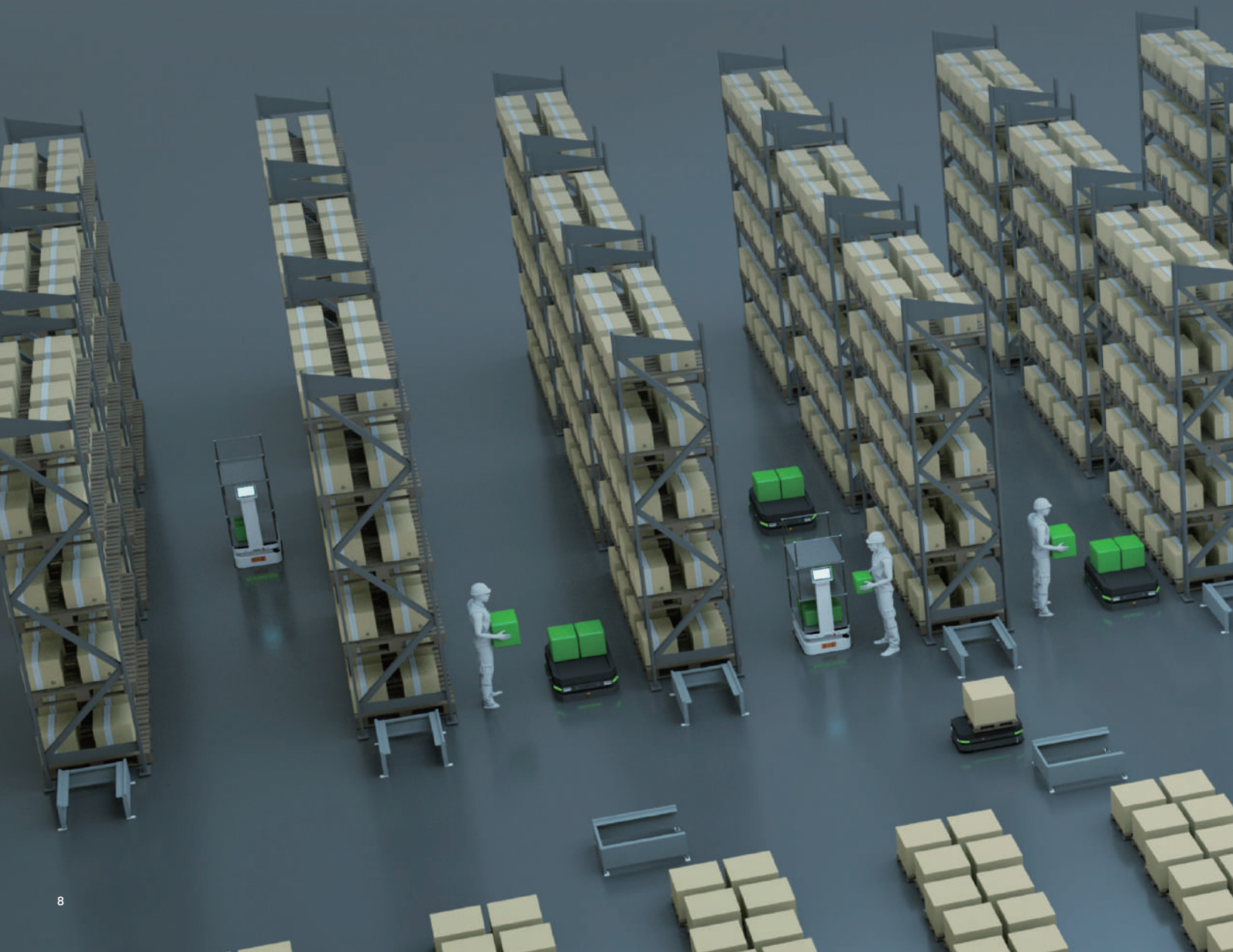

Industries



3PL



Wholesale



Omnichannel

Results We Deliver

Productivity: 2x–3x UPH Increase

ForwardX solutions increase productivity through consolidated workflows that reduce wasted time and increase output. Double or even triple your pickers' units picked per hour by removing insignificant tasks.

Accuracy: Up to 99.9% Picking Accuracy

Instead of pick lists, f(x) organizes and distributes orders directly to employees. Use on-screen visual directions and onboard RFID scanning, so your workers can pick correctly the first time, every time.

Payback: ROI in Under 9 Months

ForwardX solutions deliver immediate results. See a marked improvement and financial gain in under 2 weeks, and get a guaranteed return on investment in less than 9 months.

Efficiency: 60% Reduction in Walking Time

AMRs handle material movements, allowing employees to focus on more important tasks. Reduce traveling, picking, and order reviewing time to achieve more in a shorter period.

Savings: 50% Reduction in Labor Costs

AMRs address recruitment and turnover issues by increasing productivity and worker satisfaction. Automate repetitive workflows and redistribute your work force to cut your fully burdened labor costs in half.



DHL

DHL chose a ForwardX Flex solution to simplify picking and sorting workflows. The Flex solution consisted of a fleet of Flex 300-S AMRs with custom-built racking and f(x) Fleet Manager. The facility supports 600 retail stores with varying delivery frequencies. Increasing productivity, eliminating errors, and decreasing labor dependency was key.

Results

<2

Years ROI

3x

Productivity Increase

43%

Labor Cost Reduction



ITOCHU

ITOCHU Logistics China (ILC) chose a ForwardX Flex solution to automate picking and packing workflows in its Tianjian location. Consisting of a fleet of ForwardX Flex 300 AMRs and f(x) Fleet Manager, the solution was designed to minimize travel, reduce cognitive fatigue, lower labor dependency, and allow for rapid scalability. Onsite deployment took less than 2 weeks, and ILC was able to cut labor costs in half, double its productivity, and reach 99.99% order accuracy.

Results

2.13x

Productivity Increase

99.99%

Picking Accuracy

52%

Labor Cost Reduction



FORWARD X
ITOCHU
物流(中国)有限公司

014

Manufacturing

Workflows

Cart Transport

Use Flex L or Max L AMRs for point-to-point cart transportation, such as line delivery, WIP movement, and finished goods.

Pallet Transport

Use Max L AMRs for point-to-point pallet transportation, such as inbound receiving of raw materials, putaway, and production-to-warehouse movement.

Your Current Pain Points

Low Flexibility

SKUs are increasing, and product life cycles are decreasing. This means production lines must change to keep up, but current operations are too rigid.

Low Predictability

Manual operation lacks predictability due to complicated processes between lines with different cycles. Therefore, large material buffers are required.

High Labor Costs

Labor intensity is high, turnover is fast, and recruitment and training costs are high. This causes huge labor cost pressures for manufacturers.

High Error Rate

Complex material requirements and frequent iterations make operations complicated and lead to frequent errors.

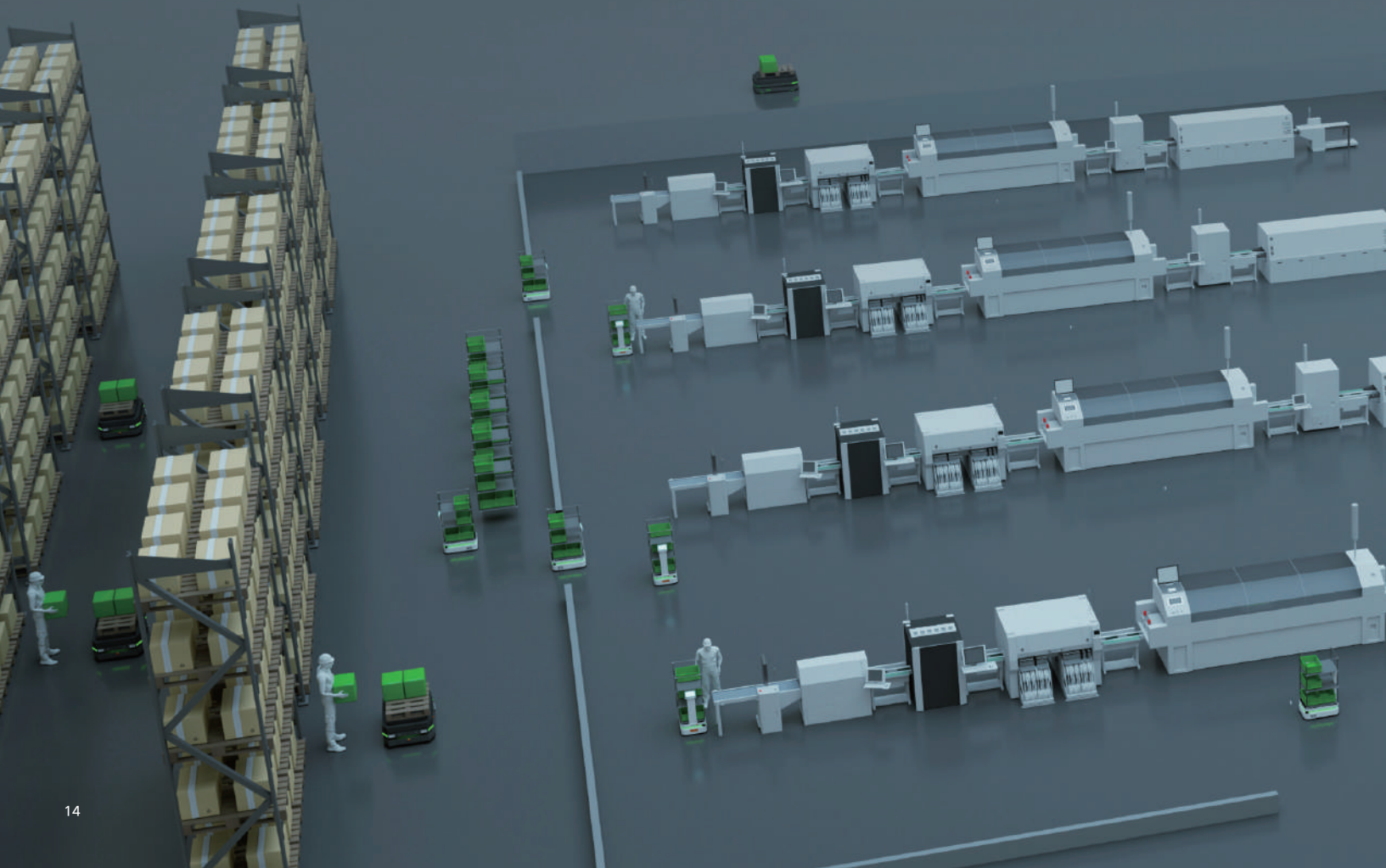

Industries



Electronics



Semiconductor



Automotive Parts



Home Appliance

Results We Deliver

Reliability: Uptime Availability of 99.5%

f(x) continuously coordinates the autonomous fleet for hands-free operations and best-in-class uptime. Automate your operations to increase predictability, reducing delays and minimizing your need for manual intervention.

Efficiency: Cycle Time Reduction

Reliable workflows improve the cadence of production and reduce waiting times. Meet your demand quicker by reducing start-to-finish production time with fewer delays.

Flexibility: Changeover Speed Increase

AMR workflows can be modified in real-time with a simple click. Reduce your changeover times and increase operational agility using f(x)'s map builder.

Savings: 50% Reduction in Labor Costs

Automating undesirable work and redeploying workers reduces recruitment requirements and keeps the workforce happy. Use ForwardX solutions to decrease turnover and bring down costs.

Payback: ROI in <2 Years

AMRs deliver a return on investment in under 2 years. Instead of waiting 5-10 years for payback, use AMRs for a quick deployment with flexible payment options, without any need for infrastructure changes.

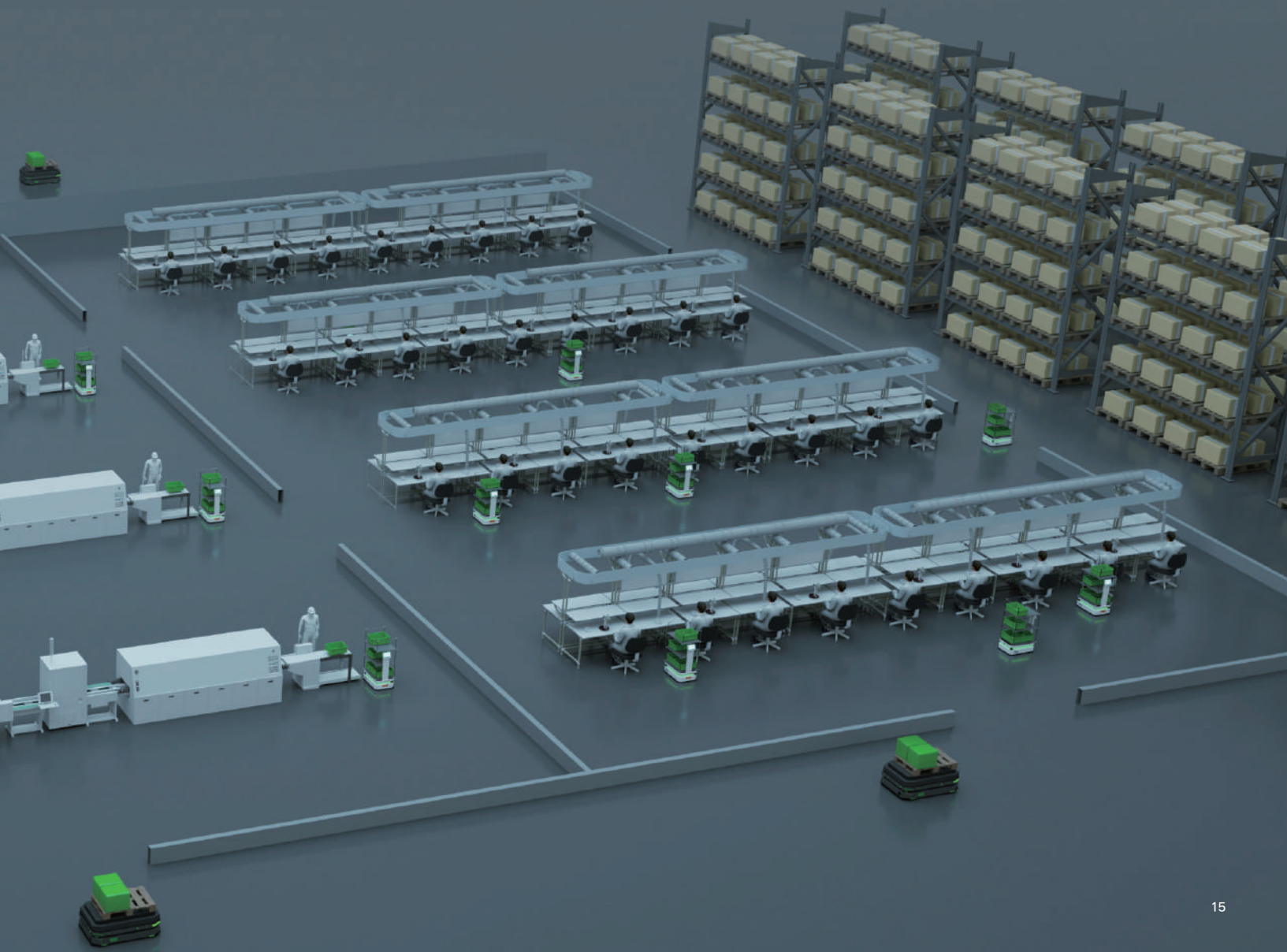

TCL



TCL chose a ForwardX Flex solution in what was the globe's first, and RBR50's Innovation Award winning, 5G-enabled AMR project to automate the movement of materials across the production facility. The solution consisted of dozens of ForwardX Flex 300-LS AMRs connected through a 5G network set up as part of TCL's 5G+ Smart Factory Initiative. The solution was designed to improve productivity, decrease labor dependency, and increase inventory turnover.

Results

360°

Obstacle Avoidance for Safe Navigation

99.5%

Uptime Availability

1st

5G-Enabled AMR Project Worldwide



Automotive: Warehouse-to-Line

Solutions

End-to-End Production Support

From receiving of raw materials, to warehouse picking, production line delivery, finished goods handling, and outbound staging, ForwardX provides a comprehensive set of solutions for automotive manufacturing.

Efficient Digitalization

Achieve full traceability of parts and process through digitization with smart automation.

Challenges

Complex Workflows

Coordination and orchestration of complex processes is difficult with manual operations. Automation adds a level of transparency and control that leads to more efficient production flow.

Low Flexibility

In today's changing landscape, rigid infrastructure & operations are no longer viable options to achieve output KPIs.

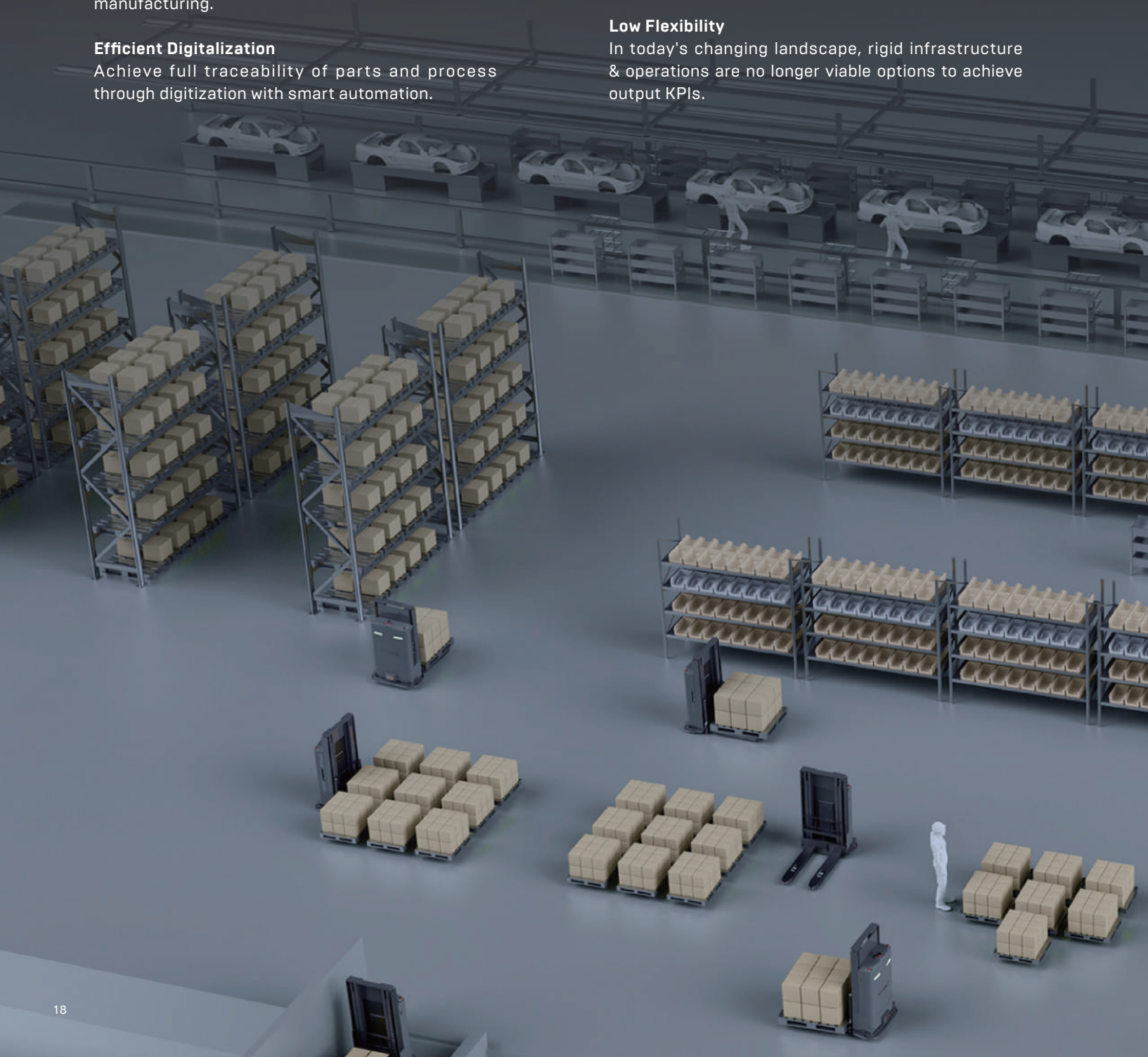

Delivering Value

Autonomous Material Transport

Automatically organize and deliver KLT, GLT, SLT, and other materials in batch and JIT workflows.

Industry 4.0

Digital Optimization

Analysis of robot operational data through smart BI and visualization tools, ForwardX helps you optimize your operations for maximum efficiency in real-time.

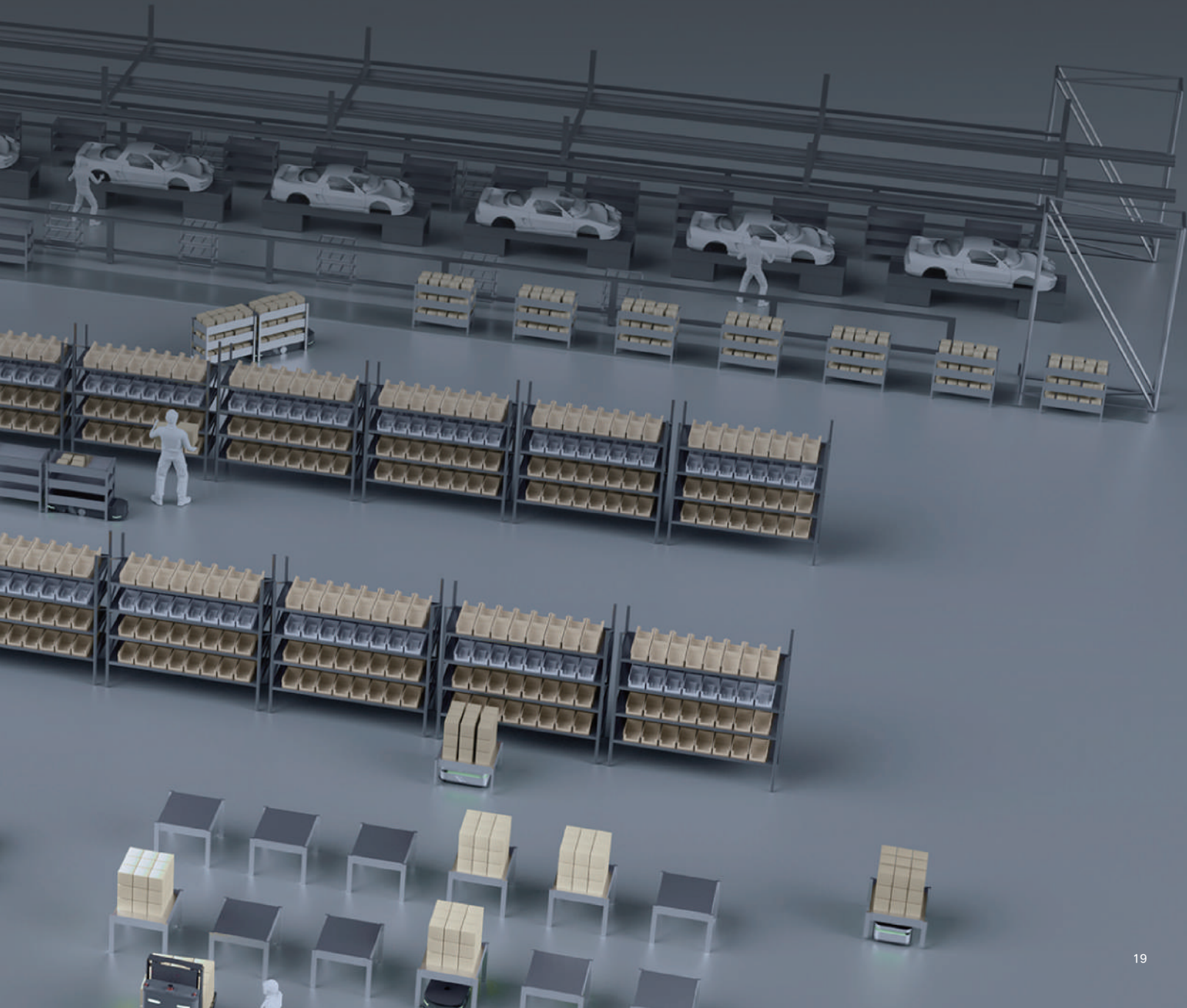

SERES

SERES Automobile Co., Ltd. is an electric vehicle (EV) and new energy vehicle (NEV) company. ForwardX Robotics deployed its Lynx series AMRs and f(x) Fleet Manager at a SERES manufacturing plant as part of a digital transformation. The project covers the final assembly workshop's assembly line, the raw material warehouse, and the fixed rotor workshop. The robots handle roughly 100 logistics tasks daily in the material collection and distribution area, the line-side storage area, and between production lines. Through practical applications, the employees on the SERES production line have significantly reduced the labor intensity of material handling and achieved digital data management and unmanned material distribution.

Pain Points

Fast-paced, changing industry

Constant production and assembly line changes

Inflexible and difficulty in adapting to new layouts



Customer Value

Intelligent task management efficiently adapts to changes

Quick deployment for various scenarios

Flexible and scalable to meet production requirements

±0.2 in

Precision Docking

Autonomous

Changeover Between Empty and Full Containers



ForwardX Matrix

The Flexible Automation Platform

ForwardX Matrix seamlessly connects with your existing software infrastructure. Once WMS is connected, the platform autonomously orchestrates your operations for maximum productivity while offering you deep insight into and control of every inch of your facility.



Top Modules and Add-ons for Smart Warehousing

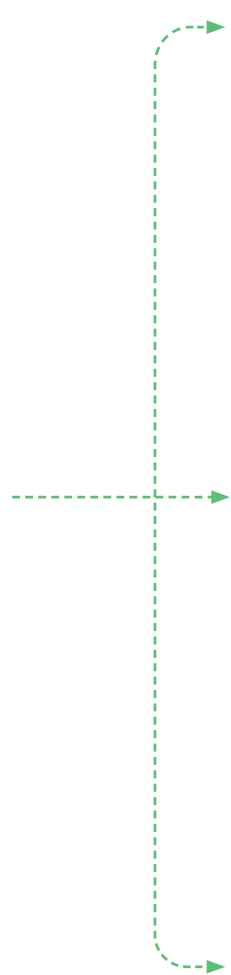

Powered by
ForwardX Cortex

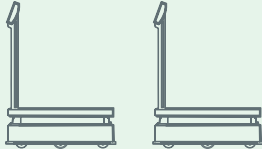

ForwardX Flex®
Visual Autonomous Mobile Robots
for up to 600kg (1,322 lbs)

Perfect for small to medium load movements like picking, Flex AMRs collaborate with human workers to remove unproductive tasks like long-distance walking and increase the efficiency and accuracy of human work.



ForwardX Max®
Visual Autonomous Mobile Robots
for up to 2,500 kg (5,511 lbs)

Built for medium to high payloads up to 2,500 kg (5,511 lbs) , Max and Max L AMRs support the automation of multiple workflows across your warehouse including heavy piece, case, and pallet picking.

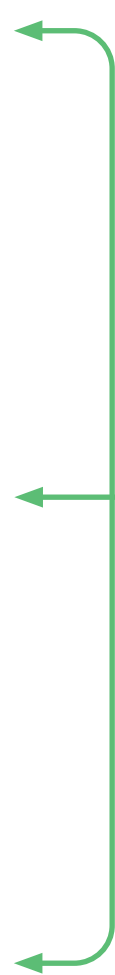



Your Systems
WMS, WCS

Seamlessly connects with f(x) through API integration, transmitting vital data back and forth from f(x).

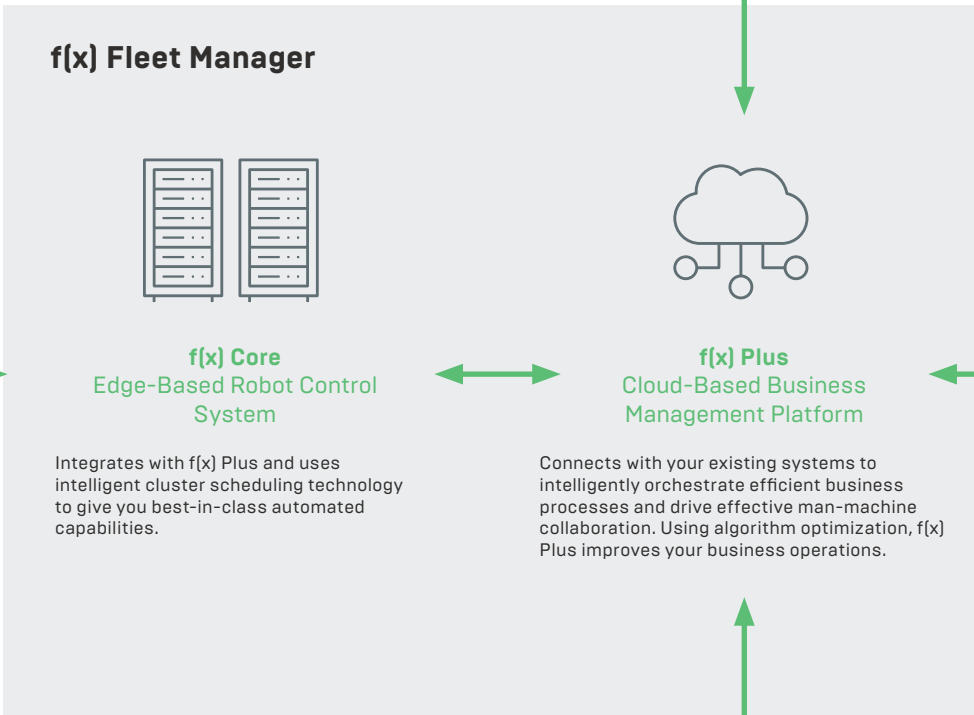

Integrates with f(x) Plus and uses intelligent cluster scheduling technology to give you best-in-class automated capabilities.

Connects with your existing systems to intelligently orchestrate efficient business processes and drive effective man-machine collaboration. Using algorithm optimization, f(x) Plus improves your business operations.



Tailored Scenario for Smart Warehousing



Other Scenarios (Retail, Health)



f(x) Dashboard
Desktop Application

Built for management level staff to control operations, track performance, and analyze data, f(x) Dashboard gives you a birds-eye view of your facility.



f(x) Mobile
Mobile Application for PDAs, Smart Watches, and Cellphones

Used by warehouse operators, supervisors, and other staff on the floor, f(x) Mobile improves human performance through directed workflows that help workers focus on value-adding activities.

ForwardX Flex AMRs

Intelligently Reshaping Warehousing and Manufacturing Business Processes

The Flex 300-L is specifically designed for ultra-narrow aisles, allowing for agile navigation in confined workspaces. Equipped with a lightweight body and an intelligent lifting system, it can adapt to narrow aisle challenges.

The Flex 300-LS is equipped with a lifting function for autonomous rack docking and an interactive touchscreen with customizable UI for operation efficiency improvement.

The Flex 300-SCB is tailored for warehouse picking and sorting tasks. Its compact design is ideal for narrow aisles, greatly improving operational space flexibility and efficiency. Additionally, it offers optional printer and barcode scanner integration for enhanced functionality.



Flex 300-L



Flex 300-LS



Flex 300-SCB



Flex 300-L



Flex 300-LS



Flex 300-SCB

Dimensions

Length	850 mm (33.46 in)	850 mm (33.46 in)	850 mm (33.46 in)
Width	480 mm (18.89 in)	480 mm (18.89 in)	480 mm (18.89 in)
Height	295 mm (11.61 in)	295 mm (11.61 in)	295 mm (11.61 in)
Turning Diameter	960 mm (37.79 in)	960 mm (37.79 in)	1,100 mm (43.30 in)
Ground Clearance	25 mm (0.98 in)	25 mm (0.98 in)	25 mm (0.98 in)
Load Surface	640x370 mm (25.19x14.56 in)	640x370 mm (25.19x14.56 in)	780x500 mm (30.70x19.68 in)
Lifting Height	60 mm (2.36 in)	60 mm (2.36 in)	-

Payload

Weight	120 kg (264 lbs)
Max. Payload	300 kg (661 lbs)

Performance

Navigation Mode	Real-time Optimal / Road Network / Hybrid
Positioning Mode	Laser SLAM / Visual / Ground QR code / Wall QR Code

Communication

Wi-Fi (IEEE 802.11a/b/g/n/ac)	Yes
Wi-Fi (IEEE 802.11ax)	Optional
Cellular Network (Public 4G/5G)	Optional

Power

Endurance	~8 hrs Per Charge
Charging Mode	DC CC-VC

Sensors

LiDAR	4
UWA Cameras	1 (Front)
3D Cameras	1 (Front)
Odometer	1
IMU	1

Interaction

Audio	Yes
Lights	Yes
Configuration Screen	-

Safety

Safety Bumper	Yes	Yes	Yes
Emergency Stop Button	1	1	2
Movement Obstacle Perception	Yes	Yes	Yes
Audible And Visual Alarm	Yes	Yes	Yes
Pallet Hump	Optional	Optional	-

Compliance

CE	Yes
----	-----

ForwardX Flex AMRs

Intelligently Reshaping Warehousing and Manufacturing Business Processes

The Flex 600-L boasts a thinner and sleeker body design, increased payload capacity, and an intelligent lifting system, making it compatible with a wider range of racks and carts. This new model is equipped with four LiDAR sensors for 360-degree obstacle recognition and avoidance.

The Flex 600-LS features an intuitive touchscreen for enhanced operational efficiency, a lifting function that handles payloads up to 600 kg (1,322 lbs), and a thinner design for improved adaptability to various container types.

Flex 600-ST is a one-of-a-kind towing AMR. Equipped with an on-board screen for streamlined workflows, and advanced sensors offering complete 360° obstacle recognition, this autonomous tugger is the epitome of safety and efficiency. Let Flex 600-ST handle all the tugging, towing, and pulling, to revolutionize your warehouse operations.



Flex 600-L



Flex 600-LS



Flex 600-ST



Flex 600-L



Flex 600-LS



Flex 600-ST

Dimensions	Length	950 mm (37.40 in)	950 mm (37.40 in)	1,300 mm (51.18 in)
	Width	650 mm (25.59 in)	650 mm (25.59 in)	650 mm (25.59 in)
	Height	245 mm (9.64 in)	1,185.5 mm (46.67 in)	1,240 mm (48.81 in)
	Turning Diameter	1,120 mm (44.09 in)	1,120 mm (44.09 in)	1,660 mm (65.35 in)
	Ground Clearance	20 mm (0.78 in)	20 mm (0.78 in)	20 mm (0.78 in)
	Load Surface	950x650 mm (37.40x25.59 in)	858x650 mm (33.77x25.59 in)	-
	Lifting Height	60 mm (2.36 in)	60 mm (2.36 in)	-
Payload	Weight	150 kg (330 lbs)	160 kg (352 lbs)	180 kg (396 lbs)
	Max. Payload	600 kg (1,322 lbs)	600 kg (1,322 lbs)	-
Function	Towing Module	-	-	Yes
	Towing Capacity	-	-	600 kg (1,322 lbs)
	Ground Clearance (Towing Module)	-	-	120-320 mm (4.72-12.59 in) (Customizable)
Performance	Navigation Mode	Real-time Optimal / Road Network / Hybrid		
	Positioning Mode	Laser SLAM / Visual / Ground QR code / Wall QR Code		
Communication	Wi-Fi (IEEE 802.11a/b/g/n/ac)	Yes		
	Wi-Fi (IEEE 802.11ax)	Optional		
	Cellular Network (Public 4G/5G)	Optional		
Power	Endurance	~8 hrs Per Charge	~8 hrs Per Charge	~5.5 hrs Per Charge
	Charging Mode	DC CC-VC	DC CC-VC	DC CC-VC
	Q.D.	-	-	Yes
Sensors	LiDAR	4	4	3
	UWA Cameras	1 (Front)+1 (Side)	1 (Front)+1 (Side)	1 (Front)+1 (Side)
	3D Cameras	1 (Front)	1 (Front)	-
	Odometer	1	1	1
	IMU	1	1	1
Interaction	Audio	Yes		
	Lights	Yes		
	Configuration Screen	Yes		
Safety	Safety Bumper	Yes	Yes	Yes
	Emergency Stop Button	2	2	2
	Movement Obstacle Perception	Yes	Yes	Yes
	Audible And Visual Alarm	Yes	Yes	Yes
	Pallet Hump	Optional	Optional	-
Compliance	CE	Yes		

ForwardX Conveyor AMRs

Automatic Loading, Unloading, and Docking with AS/RS

ForwardX Conveyor AMRs are suitable for transporting and handling a variety of containers including totes and pallets. They can be incorporated with your existing production lines or automatic storage and retrieval systems (AS/RS).

Our Conveyor AMRs are extensions of our Flex and Max series. Depending on your business needs, these AMRs can be customized to include up to two layers and two rows of rollers, such as one row on the bottom layer with two rows on the top layer.

Conveyor accessories can be customized according to customer requirements.





Flex 300 Conveyor
[2 Layers, 2 Rows]

Length	1,050 mm (41.30 in)
Width	650 mm (25.60 in)
Height	1,186 mm (46.70 in)
Payload Capacity	50 kg (110 lbs) per shelf
Load Surface Area	650x365x200 mm (25.60x14.30x7.90 in)
Loading Height	Bottom Layer: 555 mm (21.80 in) Top Layer: 1,150 mm (45.30 in)



Flex 300 Conveyor 1 Layers, 2 Rows



Flex 300 Conveyor 2 Layers, 1 Row



Flex 300 Conveyor 1 Layer, 1 Row

ForwardX Max AMRs

Point-to-Point, End-to-End Smart Transportation

Max 1500-L is specifically designed for case picking applications. With full 360° obstacle detection and avoidance, a loading capacity of 1,500 kg (3,306 lbs), highly precise docking capabilities and lifting functions for pallets and racks, it excels in safely and efficiently transporting medium-sized and heavier goods in case picking scenarios.

Max 02500-L supports omnidirectional towing with a maximum load capacity of 2,500 kg (5,511 lbs), capable of operating flexibly in relatively restricted working environments, greatly enhancing the flexibility and safety of production lines. At the same time, the AMR is equipped with a powerful jacking system that can support the jacking of oversized shelves, helping to improve productivity and ease of work.



Max 1500-L



Max 02500-L



Max 1500-L

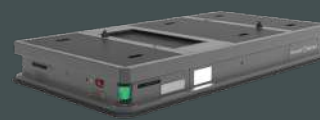

Max 02500-L

Dimensions

Length	1,250 mm (49.21 in)	2,100 mm (82.67 in)
Width	850 mm (33.46 in)	1,100 mm (43.30 in) [Customizable]
Height	245 mm (9.64 in)	310 mm (12.20 in) [Customizable]
Turning Diameter	1,340 mm (52.75 in)	2,239 mm (88.14 in)
Ground Clearance	25 mm (0.98 in)	30 mm (1.18 in)
Load Surface	1,200x830 mm (47.24x32.67 in)	2,100x1,100 mm (82.67x43.30 in)
Lifting Height	60 mm (2.36 in)	145 mm (5.70 in)

Payload

Weight	250 kg (551 lbs)	700 kg (1,543 lbs)
Max. Payload	1,500 kg (3,306 lbs)	2,500 kg (5,511 lbs) [Customizable]

Performance

Navigation Mode	Real-time Optimal / Road Network / Hybrid / Following
Positioning Mode	Laser SLAM / Visual / Optional QR Code Navigation

Communication

Wi-Fi (IEEE 802.11a/b/g/n/ac)	Yes
Wi-Fi (IEEE 802.11ax)	Optional
Cellular Network (Public 4G/5G)	Optional

Power

Endurance	~8 hrs Per Charge	~7 hrs Per Charge
Charging Mode	DC CC-VC	DC CC-VC
Q.D.	-	Yes

Sensors

LiDAR	4	2
UWA Cameras	1 (Front)+1 (Right)	2 (Front)+2 (Side)
3D Cameras	Optional	Optional
QR Code Cameras-downward	Yes	Yes
Odometer	Yes	Yes
IMU	Yes	Yes

Interaction

Audio	Yes
Lights	Yes
Configuration Screen	Yes

Safety

Safety Bumper	Yes	Yes
Emergency Stop Button	2	2
Movement Obstacle Perception	Yes	Yes
Audible And Visual Alarm	Yes	Yes
Pallet Hump	Optional	-

Compliance

CE	Yes	-
----	-----	---

ForwardX Lynx AMRs

Redefining Flexibility in the Automotive Industry

The Lynx series is designed to solve pain points in the automotive manufacturing industry. Lynx uses deep learning computer vision paired with a LiDAR-based SLAM navigation system making it suitable for stable operations in a complex environment. It works alongside personnel, other AMRs, and customers' existing automation equipment without a need for remodeling or laying out magnetic strips or other fixed routes. Lynx is the most flexible AMR built for the automotive industry that is driving efficiency with rapid deployment and leading to quick ROI.



Lynx U1000

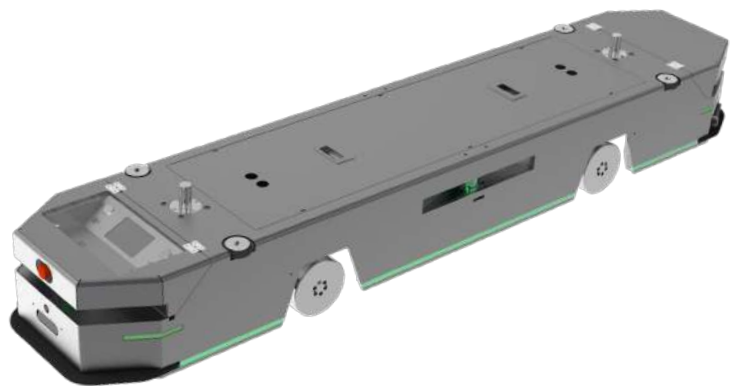

Lynx O1500



Lynx U1000

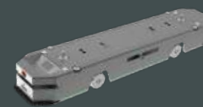

Lynx O1500

Dimensions

Length	1,250-1,550 mm [49.21~61.02 in] [Customizable]	2,200 mm [86.61 in]
Width	440 mm [17.32 in]	440 mm [17.32 in]
Height	285 mm [11.22 in]	285 mm [11.22 in]
Turning Diameter	3,108 mm [122.36 in]	2,254 mm [88.74 in]
Ground Clearance	25 mm [0.98 in]	25 mm [0.98 in]
Lifting Height	50 mm [1.96 in]	50 mm [1.96 in]

Payload

Weight	240 kg [529 lbs]	340 kg [749 lbs]
Max. Payload	1,000 kg [2,204 lbs]	1,500 kg [3,306 lbs]

Performance

Navigation Mode	Real-time Optimal / Road Network / Hybrid
Positioning Mode	Laser SLAM / Visual / Optional QR Code Navigation

Function

Towing Hook	1	2
-------------	---	---

Communication

Wi-Fi (IEEE 802.11a/b/g/n/ac)	Yes
Wi-Fi (IEEE 802.11ax)	Optional
Cellular Network (Public 4G/5G)	Optional

Power

Endurance	~8 hrs Per Charge	~9 hrs Per Charge
Charging Mode	DC CC-VC	DC CC-VC
Q.D.	Yes	Yes

Sensors

LiDAR	1	4
UWA Cameras	1 (Front)	2 (Front)
3D Cameras	Optional	Optional
QR Code Cameras-downward	Yes	Yes
Odometer	Yes	Yes
IMU	Yes	Yes

Interaction

Audio	Yes
Lights	Yes
Configuration Screen	Yes

Safety

Safety Bumper	Yes
Emergency Stop Button	2
Movement Obstacle Perception	Yes
Audible And Visual Alarm	Yes

Compliance

CE	Yes
----	-----

ForwardX Apex AMRs

The Optimal Autonomous Forklift

Apex series autonomous forklifts are divided into three types: Apex 1400-L pallet stacker forklift, Apex C1500-L counterbalanced forklift, and Apex 2000 pallet jack forklift.

Apex 1400-L CAPACITY CHART

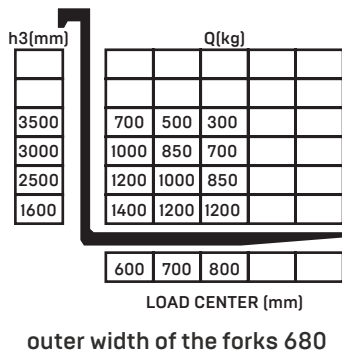

Apex C1500-L CAPACITY CHART

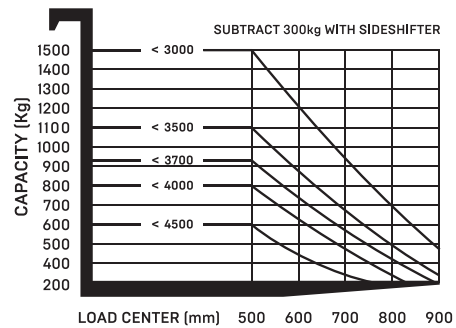
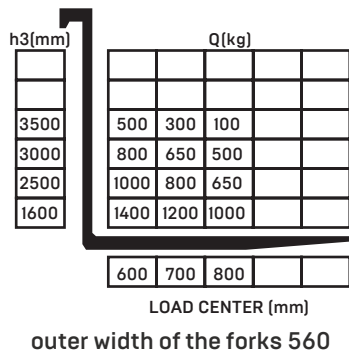

***For Apex 1400-L:**

When the outer width of the forks is greater than 620, the load curve is executed according to a width of 680. When the outer width of the forks is between 560 and 620, the load curve is executed according to a width of 560.



Apex 1400-L



Apex C1500-L



Apex 2000



Apex 1400-L



Apex C1500-L



Apex 2000

Dimensions

Length	1,830 mm (72.04 in)	2,495 mm (82.22 in)	1,725 mm (67.91 in)
Width	1,050 mm (41.33 in)	1,250 mm (49.21 in)	1,050 mm (41.33 in)
Height	2,080 mm (81.88 in)	2,190 mm (86.22 in)	2,090 mm (82.28 in)
Turning Diameter	2,260 mm (88.97 in)	2,750 mm (108.26 in)	3,152 mm (124.09 in)
Aisle Width (Ast)	2,547 mm (100.27 in)*	3,186 mm (125.43 in)*	2,456 mm (96.69 in)*

Payload

Weight	880 kg (1,940 lbs)	2,700 kg (5,952 lbs)	400 kg (881 lbs)
Max. Payload	1,400 kg (3,086 lbs)	1,500 kg (3,306 lbs)	2,000 kg (4,409 lbs)

Function

Fork Dimensions	1,160/170/60 mm (45.66/6.69/2.36 in)	1,070/122/40 mm (42.12/4.80/1.57 in)	1,200/170/40 mm (47.24/6.69/1.57 in)
Fork Carriage Width	680/560 mm (26.77/22.04 in)	680/560/460 mm (26.77/22.04/18.11 in)	680/560 mm (26.77/22.04 in)
Default Fork Height	85 mm (3.34 in)	40 mm (1.57 in)	85 mm (3.34 in)
Max. Fork Height (Customizable)	1,600 mm (62.99 in)-1,400 kg (3,086 lbs)	3,000 mm (118.11 in)-1,500 kg (3,306 lbs)	195 mm (7.67 in)
Load Center Distance	3,500 mm (137.79 in)-700 kg (1,543 lbs)	4,500 mm (177.16 in)-600 kg (1,322 lbs)	-
Pallet Compatibility	600 mm (23.62 in)	500 mm (19.68 in)	600 mm (23.62 in)
Pallet Compatibility	Euro Pallets, Customized Pallets*	Euro Pallets, GMA Pallets, Customized Pallets*	Euro Pallets, Customized Pallets*

Performance

Navigation Mode	Road Network / Preferred Route / Real-time Optimal	Road Network / Preferred Route / Hybrid	Road Network / Preferred Route / Hybrid
Positioning Mode	Laser SLAM / Visual Semantics	Laser SLAM / Visual Semantics / Optional QR Code Navigation	Laser SLAM / Visual Semantics

Communication

Wi-Fi (IEEE 802.11a/b/g/n/ac)	Yes
Wi-Fi (IEEE 802.11ax)	Optional
Cellular Network (Public 4G/5G)	Optional

Power

Endurance	~10 hrs Per Charge	~8 hrs Per Charge	~4 hrs Per Charge
Charging Mode	DC CC-VC	DC CC-VC	DC CC-VC

Sensors

Lidar	5 (TSA:2 AMR:2+1)	5 (TSA:2 AMR:2+1)	5 (TSA:2 AMR:2+1)
Pallet In-Place Sensor	2	2	2
Pallet Off-Position Sensor	2	2	-
QR Code Cameras-downward	-	Optional	-

Safety

Safety Bumper	Yes
Emergency Stop Button	2

Compliance

CE	Yes
----	-----

Reflex Charging Station

Smart, Robust and Space-efficient

The ForwardX Reflex charging station serves as a crucial component, providing essential charging support for the fleet. It handles charging tasks with impressive speed and energy capacity, incorporating multiple safety protections to safeguard both employees and AMRs within your facility.

Three available models are compatible with different series of AMRs.



CS- 30050-S
CS- 30100-S



CS- 40070-GD



CS-30050-S



CS-30100-S



CS-40070-GD

Dimensions

Length	600 mm (23.62 in)	600 mm (23.62 in)	600 mm (23.62 in)
Width	300 mm (11.81 in)	300 mm (11.81 in)	300 mm (11.81 in)
Height	285 mm (11.22 in)	285 mm (11.22 in)	285 mm (11.22 in)
Weight	30 kg (66 lbs)	30 kg (66 lbs)	30 kg (66 lbs)
Contact Mount Bracket Length	73 mm (2.87 in)	73 mm (2.87 in)	-
Contact Mount Ground Clearance	95 mm (3.74 in)	120 mm (4.72 in)	10.5 mm (0.41 in)

Input

Input Voltage	AC 220 V	AC 220 V	AC 220 V
Input Current	14 A	15 A	20 A
Rated Power	3000 W	3000 W	4000 W
Plug Type	GB/T 16A	GB/T 16A	ABC 25A

Output

Output Voltage	DC 54.75 V	DC 29.2 V	DC 54.75V
Maximum Output Current	50 A	100 A	70 A

Environment

IP Rating	IP20
Ambient Temperature Range	0-40°C
Humidity (Non-condensing)	5-85 %

Safety

Output Over Current Protection	Yes	Yes	Optional
Output Short Circuit Protection	Yes	Yes	Yes
Output Over Voltage Protection	Yes	Yes	Yes
Input Over Voltage Protection	Yes	Yes	Yes
Input Under Voltage Protection	Yes	Optional	Yes
Output High Voltage Shutdown Protection	Optional	Optional	Optional
Over Temperature Protection	Yes	Yes	Yes
Output Anti Reverse Protection	Optional	Optional	Optional

Compatibility

Compatible With AMR Series	Flex Series Max Series Apex 2000	Apex 1400-L Apex C1500-L	Max 02500-L Lynx Series
----------------------------	--	-----------------------------	----------------------------

f(x) Fleet Manager

Take Control of Your Warehouse

ForwardX f(x) Fleet Manager is an Industry 4.0-compatible solution that provides end-to-end automation and future-proof digitization. Acting as your command center, f(x) Fleet Manager connects with your software platforms to receive, optimize, and dispatch tasks in one central location.

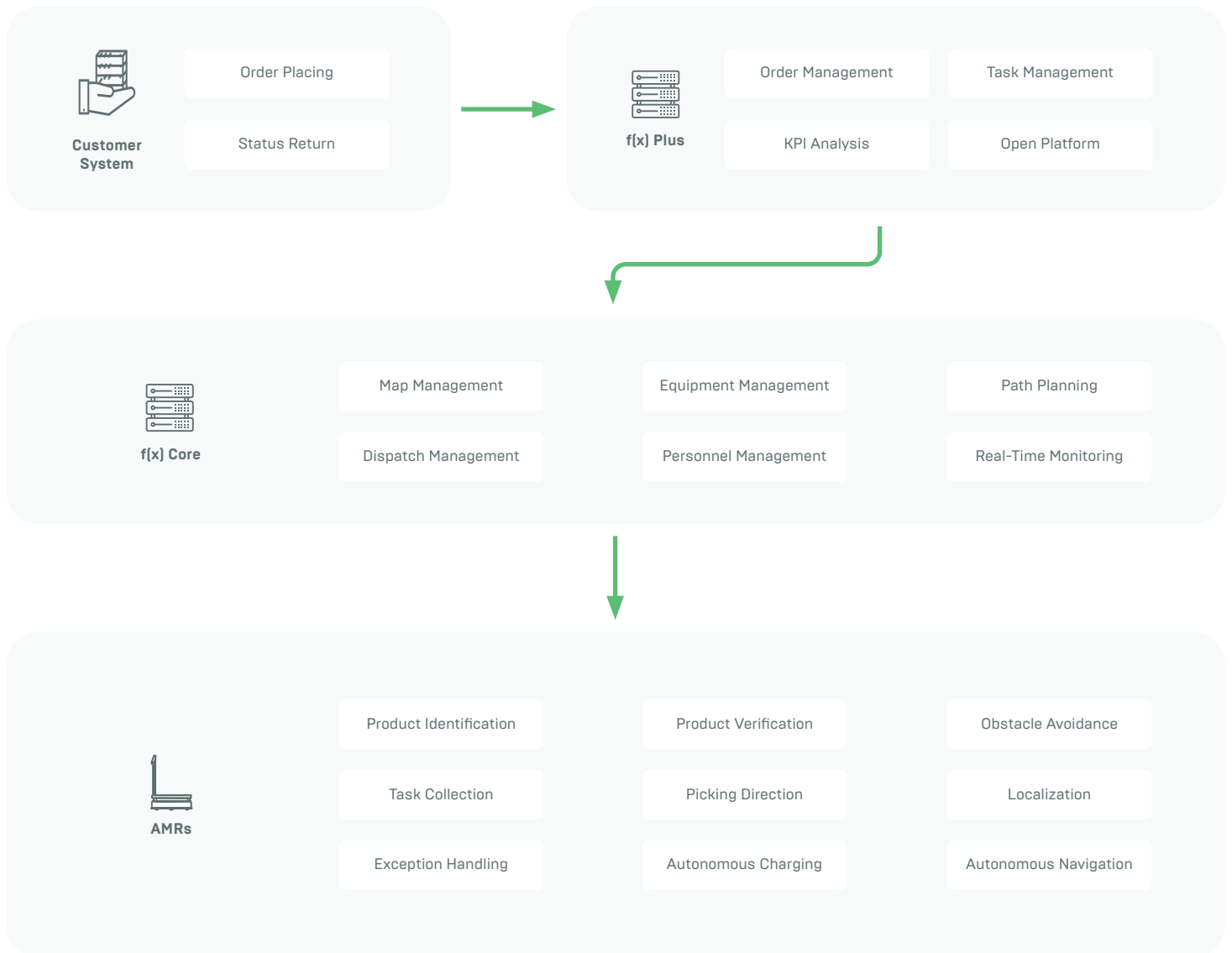

Key Features



Unmatched AMR Fleet Capacity

Expand your fleet with no growing pains. Our best-in-class machine learning algorithms ensure your Fleet Manager will intelligently manage and orient your robots to their environment, regardless of robot density, rack density, or picking strategy.



Traffic & Congestion Control

Relieve congestion and alleviate inefficiency caused by traffic with a truly intelligent solution. Our Fleet Manager provides machine learning-based traffic and congestion control to address bottlenecks, like auto-door delays from required manual intervention.



Productivity and Efficiency Tracking

Understand how productive and efficient your fleet can be as you watch in real-time. Our dashboards provide customization so that you can see exactly how your fleet operates, helping you make changes where they matter.



Optimized Battery Management for 24/7 Operation

Benefit from superior uptime effortlessly. ForwardX's Fleet Manager automatically optimizes a battery management schedule to keep your site moving forward non-stop.

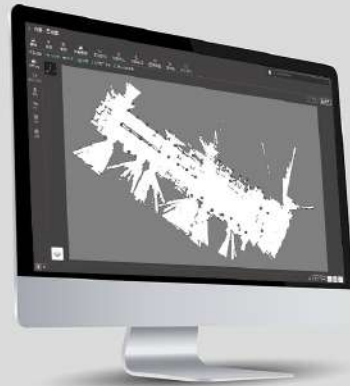

Intelligent Job Assignment

f(x) receives, organizes, and assigns tasks according to your operational strategy. Constantly monitoring and anticipating your operations, f(x) reduces wasted time and movement by using Artificial Intelligence to assign tasks for the best results.



Automatic Updates

f(x) provides automatic over-the-air updates to every AMR within your fleet to ensure your fleet is up to date with our latest improvements.



Seamless Integration

f(x) connects to your existing operational systems, such as your WMS, MES, or ERP, without any hassle. Once connected, f(x) circulates tasks across your fleet automatically and in real-time.



Smart Device Collaboration

If you have elevators or automatic doors in your facility, f(x) empowers your fleet to intelligently interact with and navigate through tricky environments. For example, f(x) allows Flex AMRs to wait for and enter elevators together.



Optimized Utility

ForwardX solutions are made to be flexible and versatile to enable you to put them to work across your facility. Based on the tasks available, f(x) will ensure that your robots contribute value wherever possible.



Customizable Dashboards

In f(x), you can customize the way you see data, prioritizing metrics most important to you. With the data constantly at your fingertips, you can create actionable plans to improve your business.

About ForwardX

ForwardX Robotics is a global leader in vision-based AMR technology, delivering innovative end-to-end material handling solutions for warehousing and manufacturing facilities. With its advanced fleet management software and the widest range of vision-first Autonomous Mobile Robots (AMRs), ForwardX Robotics helps businesses achieve higher performance and value within their supply chain operations. The company is comprised of over 250 members hailing from top universities and leading enterprises around the world. As shown by the 350+ patents and its award-winning research work, such as Frost & Sullivan's Best Practices Award and Robotics Business Review's RBR50 Innovation Award, ForwardX Robotics continues to push the boundaries of innovation.

ForwardX has deployed over 3,000 AMRs in over 220 facilities across 5 continents. With offices in the US, Japan, Korea, and China along with partnerships around the globe, ForwardX is expanding and applying its proven solutions to empower the workforce of tomorrow.



Customers

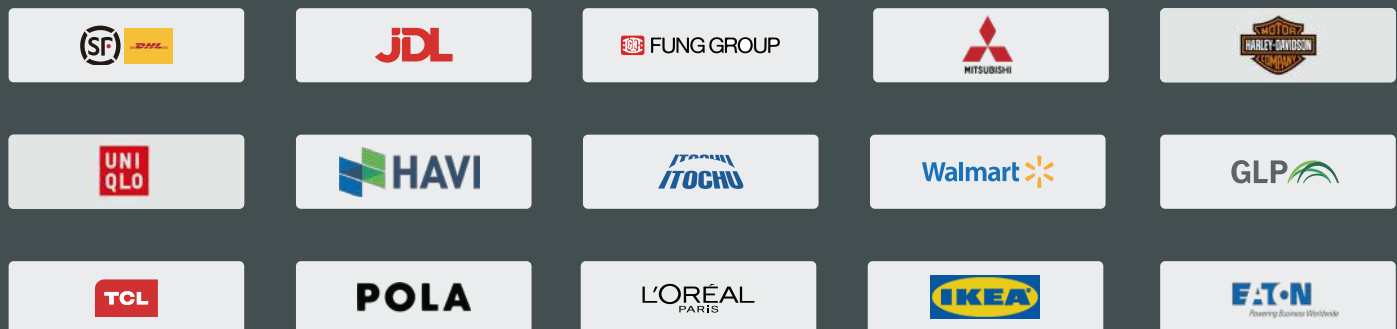

Better Performance Better Value



Sales

oversea@forwardx.com

PR & Media

pr.us@forwardx.com

Website

www.forwardx.com



@ForwardX_US



ForwardX Robotics



ForwardX Robotics

