

Robot Palletizer

A Series

Layout with automatic pallet supply

One Pallet Layout No. P01111

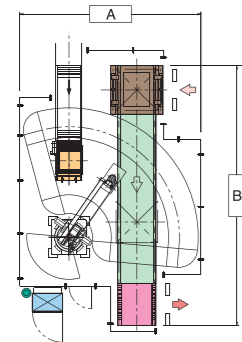

Model	A	B
A1800	4600	6900
A1800 Compact space	4300	6200
A1600	4800	6900
A700 Compact space	4200	6450
A700	5000	7200

Two Pallets Layout No. P08122

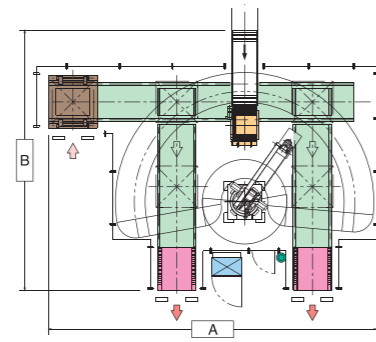

Model	A	B
A1800	8300	6900
A1800 Compact space	7795	6500
A1600	8700	6900
A700 Compact space	7700	6600
A700	8930	7200

Two Pallets Layout No. P10212

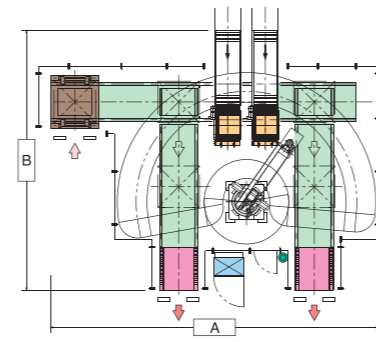

Model	A	B
A1800	8300	6900
A1800 Compact space	7795	6500
A1600	8700	6900
A700 Compact space	7700	6600
A700	8930	7200

Layout with pallet floor placement

One Pallet Layout No. F01101

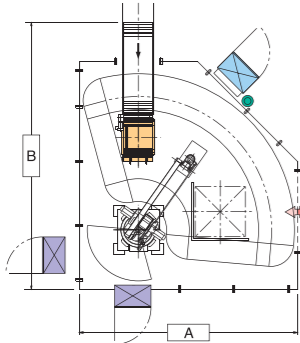

Model	A	B
A1800	4600	5850
A1800 Compact space	4300	5650
A1600	4800	5850
A700 Compact space	4200	5450
A700	5000	5850

Two Pallets Layout No. F03102

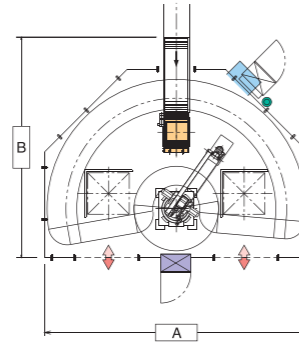

Model	A	B
A1800	6600	5850
A1800 Compact space	6000	5650
A1600	7000	5850
A700 Compact space	6000	5450
A700	7400	5850

Two Pallets Layout No. F07202

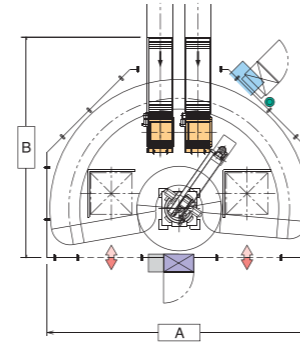

Model	A	B
A1800	6600	5850
A1800 Compact space	6000	5650
A1600	7000	5850
A700 Compact space	6000	5450
A700	7400	5850

Abbreviations
● = Air Supply = Control Panel = Pallet Conveyor = Empty Pallet → = Materials
 = Station Conveyor = Pallet Dispenser = Discharge Conveyor ⇄ = Loaded Pallet

okura OKURA YUSOKI CO., LTD.

- JAPAN** 900 Furuouchi, Noguchi-cho, Kakogawa city, Hyogo 675-8675
TEL +81-79-426-1181 FAX +81-79-426-1324
- Singapore** 211 Henderson Road #08-04 Henderson Industrial Park, Singapore 159552
TEL +65-6276-1711 FAX +65-6276-7211
- Malaysia** 3A-D, Jalan USJ 10/1A, Pusat Perniagaan USJ 10, 47610 UEP Subang Jaya, Selangor Darul Ehsan, Malaysia
TEL +60-3-8023-6381 FAX +60-3-8023-6390
- China** Rm. 304, Huawen Guojia Tower, No. 999 Zhongshan (West) Rd., Shanghai, P.R. China 200051
TEL +86-21-6275-9825 FAX +86-21-6275-9826
- U.S.A.** 301 Grove Street, Suite A, Vancouver, WA 98661, U.S.A.
TEL +1-360-735-1952 FAX +1-360-905-1707

■ The specifications are subject to change without notice.



Without a doubt, our fastest and most user-friendly Palletizing Robot ever made.



Standard speed model to Ultra high speed model



Ultra high speed model

A1800V

Capacity: 1800 cycles/hour Payload: 140kg



High speed model

A1600V

Capacity: 1600 cycles/hour Payload: 140kg



Standard speed model

A700V

Capacity: 700 cycles/hour Payload: 140kg

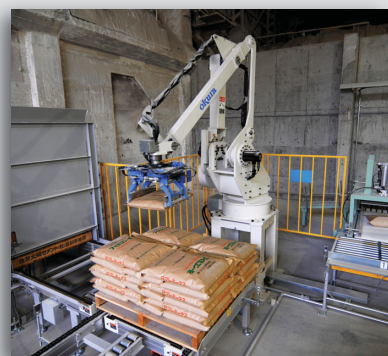

Robot Specification

Heavy Payload

The A1800V-W is able to handle up to 350kg of payload.



Large Operation Range

Having 360 degrees of rotation angle (R-axis), robot can accommodate 6 pallets in its operation range.



Eco Design

Our new Servo Controllers provide more power with a smaller motor. Reduced up to 50% consumption of power.



Increased Maximum Torque

The maximum T-axis torque of A1800V and A1600V are increased 15% from previous model.

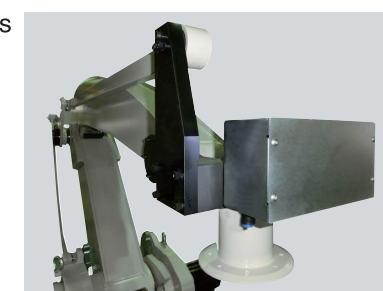

Collision Detection Function (CDF)

One of the standard features (A1600V and A1800V) of the Okura control is the Collision Detection Function (CDF). It minimizes the damage of products and / or robot during the impact from a collision.

Our Okura Robots are CE and UL Approved

The certification is done by TUV. Our robots are designed for high speed but also for high safety level.

Model	A1800V		A1600V	A700V
	A1800V	A1800V-W		
Motion System	Multi - Articulated, Polar Coordinate System			
Maximum payload	140kg (308 lbs)	350kg (771 lbs)	140kg (308lbs)	140kg (308 lbs)
Controlled Axis	4	4	4	4
Degree of operation Range	R-axis: 360 degrees D-axis: 2300mm O-axis: 1518mm T-axis: 440 degrees		R-axis: 360 degrees D-axis: 2300mm O-axis: 1750mm T-axis: 440 degrees	
Handling Rate	1800 cycles/hr	500 cycles/hr	1600 cycles/hr	700 cycles/hr
Accuracy	Repeated stop position accuracy ± 1 mm			
Robot Weight	1220kg (2690 lbs)	1300kg (2866 lbs)	1180kg (2600 lbs)	1270kg (2800 lbs)
Pneumatic Consumption	180L/min (ANR) When equipped with a pallet dispenser 300L/min(ANR)			
Ambient Temperature	0 – 40°C			
Relative Humidity	35 – 85%			
Power	6.5kVA			2.5kVA
Color	Nittoko C25-80B (Japan Painting Industry) Mancell 5Y8/1			

The Gen V controller is our most advanced controller ever!

Okura Palletizing software OXPA is now integrated in the controller. All screens for installation, operation and maintenance are user-friendly.



Built – in OXPA

Stacking programs can be created and modified directly on the controller.

You are able to create new stacking programs or edit existing stacking programs. You can modify the stacking positions, product dimensions, number of layers, change the stacking pattern, etc. directly on the touch screen of the controller.

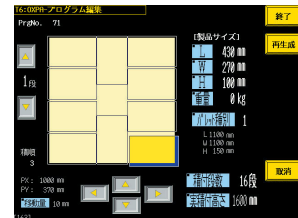

Edit position

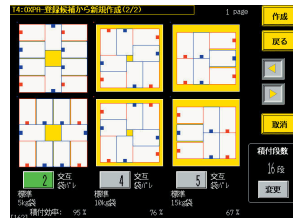

Change stacking pattern

Powerful Options

Extended range of I/O

The input/output range is extended number (3 I/O boards) to 120 IN and 96 OUT. The maximum of programming lines is expanded to 4500 lines. PLC programs can be created for larger installations.

Control for additional axis

You are able to control 2 additional axes. The optional axes can be used as C-axis (hand) or External peripheral axis (elevator, track, lifter table, shuttle etc.).



Robot on the shuttle. The robot palletize to multi places

Connection to Profibus DP and Ethernet IP

Possible field bus connections are Profibus DP and Ethernet IP.

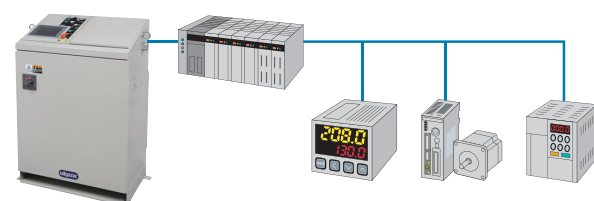

Integrated Safety PLC

The new controller is equipped with a SICK safety PLC.

- Double redundant inputs for additional external emergency stop button, safety door switch and lightguard system.
- There is the possibility to extend this safety PLC with additional I/O modules to connect multiple external emergency stop buttons, multiple safety door switches, etc.



Easy Maintenance

Exchange the data via USB memory

A USB memory port is located on the control panel. Upload/download the teaching data and production data via USB memory.

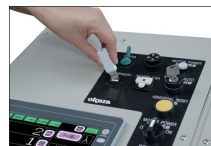

- Back up and Update OS program.
- The programs can be transferred from laptop to controller using a USB memory stick.
- Via this USB connection, stacking programs can be stored to and from USB memory, Memory backup and restore functions can be done, and system software can be transferred for upgrading the robot.

Safe and Green Robot

CE, UL and RoHS compliant

The new A700V, A1600V, A1800V and A1800V-W robots and controllers all meet RoHS, CE and UL compliance. CE robots follow the Machinery Directive and the EMC Directive. Approved by TUV.



JIS Version



CE Version

Model	JIS Version		CE Version	
	RC810 A1800V/A1800V-W/A1600V	RC820 A700V	RC810-CE A1800V/A1800V-W/A1600V	RC820-CE A700V
Dimension	800(W) × 640(D) × 1150(H) mm		940(W) × 640(D) × 1150(H) mm	
Weight	170kg (374 lbs)	165kg (363 lbs)	275kg (606 lbs)	250kg (551 lbs)
Power	Robot 6.5kVA	Robot 2.5kVA	Robot 6.5kVA	Robot 2.5kVA
	AC200V/AC220V ±5% 50/60Hz Triple-phase		AC380/400/415/480V ±10% 50Hz Triple-phase	
Color	Nittoko C25-70B5Y7/1		RAL 7035	
Display	8.4 TFT touch screen			
Servo Control	Up to control 6 axis (Control 2 optional axis)			
Ambient Temp	0 – 40°C			
Relative Humidity	35 – 85%			

Standard Hand



S type
(For cardboard cases)

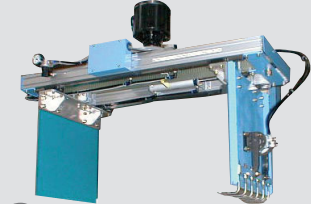

C type
(For cardboard cases)

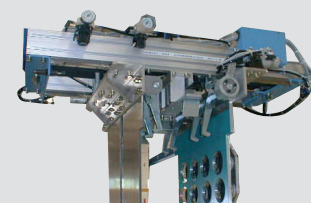

KP type
(For both cardboard cases and P boxes)

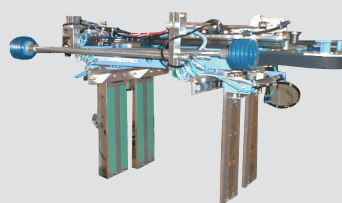

DA type
(For tied cardboard bundies)



F type
(For both cardboard cases and P boxes)

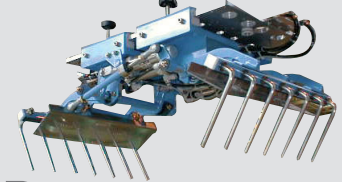

B type
(For bags)



New OXPA-QmV Palletizing Software

Offline Teaching

The stacking programs can be downloaded to the controller from remote location.

User-friendly

3D drawings for user friendly and visual software.
Windows based standard items are used (such as pull down lists, popup windows, etc.)
Clear Icons on buttons and selectors.
Communication between laptop and controller via USB cable or Ethernet, providing a faster upload and download.

More Features

Backup and restore stacking programs, download and upload system files.
Password protection for operator, production manager and system administrator.
Create and register special manually made patterns.
New pattern creator built in to OXPA-QmV.

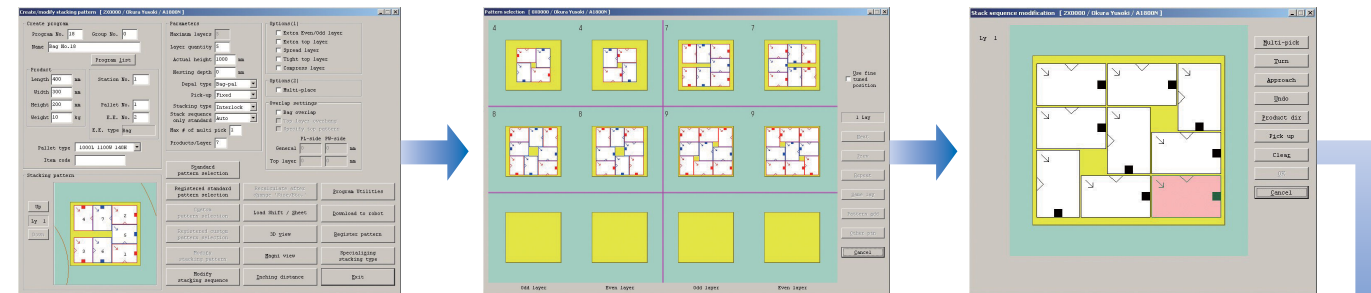
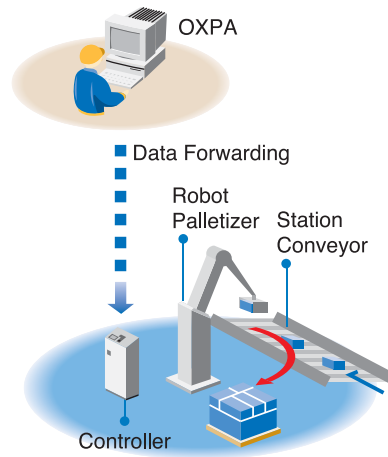

Input product dimension data.

Stacking program is automatically created after selecting a stacking pattern.

Very easy to change the stacking order and approach direction, and save this data.

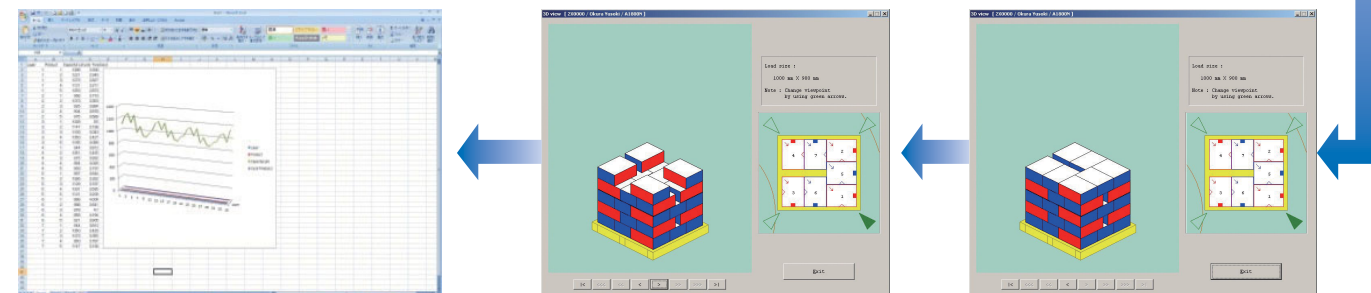

The production plan will be shown on the completed stacking pattern screen.

Capability to add the special stacking pattern to the top layer.

Visually check the completed stacking pattern.

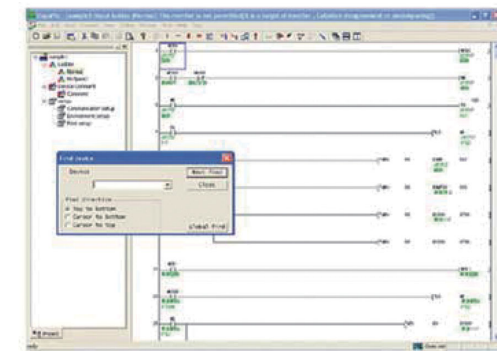

OXPA PLC Software

PLC as a Standard Feature

Okura robot palletizer control panels are supplied with a built-in PLC as a standard feature.

More Features

The maximum of programming lines is extended up to 4500 lines. PLC program can be created for larger installations.
The communication words between internal PLC and POD screen are extended and free configurable.
The communication words and bits to an external network (Profibus, Profinet, Ethernet IP) are extended (up to 96 words and 512 bits) and are now free configurable.
The download area has been extended up to 2999 random used datawords.
Faster PLC processing speed.

A1800V/A1800V-W

Unit: mm

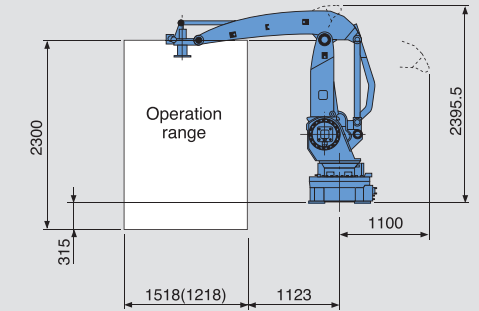
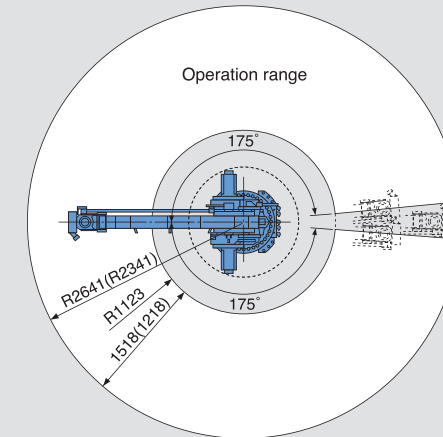

* The standard operation range of R-axis is $\pm 175^\circ$. It is possible to increase the R-axis operation range if turn OFF the R-axis limit switch.
* The values inside of parentheses are compact operation range with mechanical stopper.

A1600V

Unit: mm

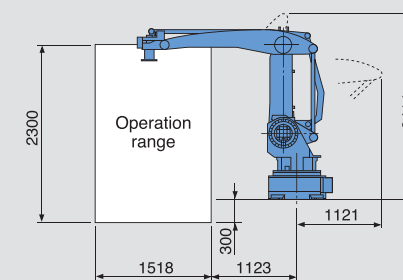
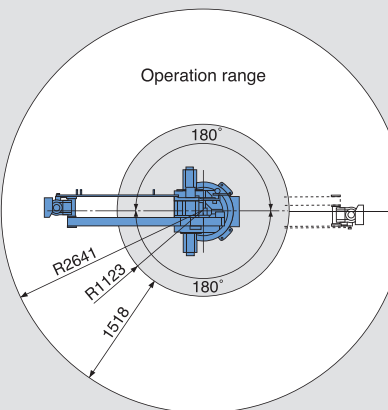

A700V

Unit: mm

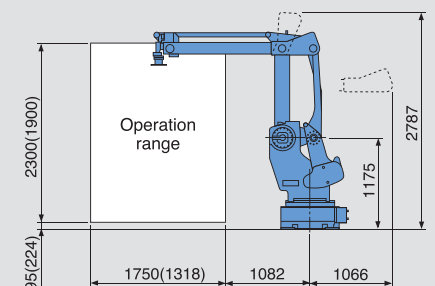
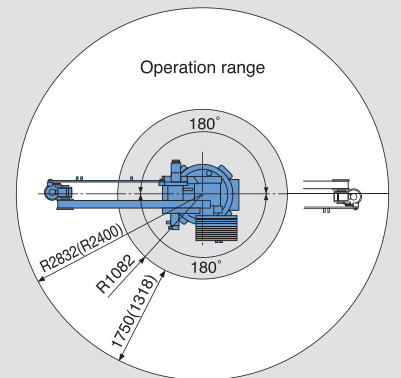

* The values inside of parentheses are compact operation range with mechanical stopper.